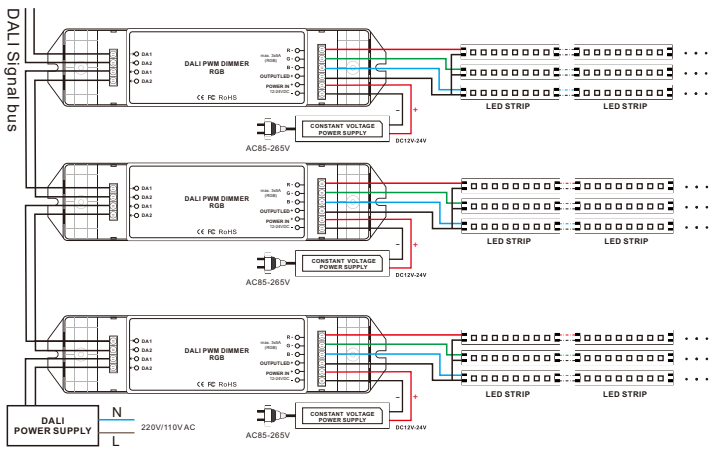

Diagram b:



7. After Sales

From the day you purchase our products within 3 years, if being used properly in accordance with the instruction, and quality problems occur, we provide free repair or replacement services except the following cases:

1. Any defects caused by wrong operations.
2. Any damages caused by inappropriate power supply or abnormal voltage.
3. Any damages caused by unauthorized removal, maintenance, modifying circuit, incorrect connections and replacing chips.
4. Any damages due to transportation, breaking, flooded water after the purchase.
5. Any damages caused by earthquake, fire, flood, lightning strike etc force majeure of natural disasters.
6. Any damages caused by negligence, inappropriate storing at high temperature and humidity environment or near harmful chemicals.

8. Kindly Reminder

Power Source Selection:
Power source must be DC constant voltage type of power supply. Due to the efficient output in some power supplies are only 80% of total, so please select at least 20% higher output power supply than the consumption of LED lights.

DALI Dimming Driver User Manual



(Please read through this manual carefully before use)

1. Brief Introduction

Welcome to use our DALI dimming driver, which input standard DALI signal and adopted the most advanced DALI standard IEC62386. It can meet with any equipment in line with the DALI protocol on a bus control, and realize the LED lighting products and traditional lighting integrate within the same set of lighting system. We also add short circuit protection, over-current protection, makes the LED lamps more stable, and to avoid the damage of the LED lamps.

2. Specifications

Model	3CH DALI dimming driver
Input voltage	DC12V-DC24V
Output current	RGB:5A/CH×3
Output Power	180W(12V)/360W(24V)
Input Signal	DALI Dimming signal
Grey Scale	4096 levels
Dimension	L176×W46×H30(mm)
Weight (G.W)	140g

3. Basic Features

1. Automatically adapts input voltage DC12V-24V.
2. can meet with any equipment in line with the DALI protocol on a bus control.
3. 4096 grey levels, lamp light soft and stable, without flickers.
4. With the DALI signal input optical isolation protection.
5. Over current protection and short circuit protection.

4. Safety warnings

1. To ensure your safety and product properly usage, please read the user manual carefully.
2. To avoid installed the product in minefield, strong magnetic field and high voltage area.

3. To ensure the wiring is correct and firm avoiding short circuit damages to components and cause fire.
4. Please install the product in a well ventilated area to ensure appropriate temperature environment.
5. The product must be worked with DC constant voltage power supply.
Please check the consistence of input power with the product, if the output voltage of the power comply with that of the product.
6. Connect the wire with the power on is forbidden. Ensure proper wiring first then check to ensure no short-circuit, then power on!
7. Don't repair it by yourself whenever an error occur. Contact the supplier for any inquiry.

5. Dimensions

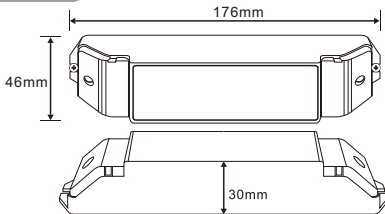

6. Conjunction Diagram

1. Active DALI bus signal input wiring diagram a: (no need to distinguish DALI bus is anode or cathode)

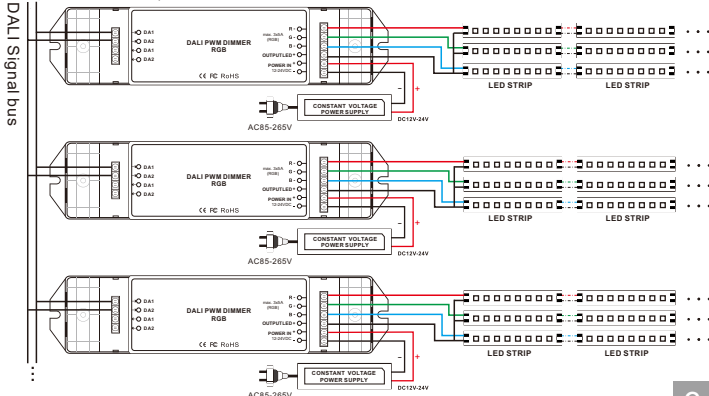
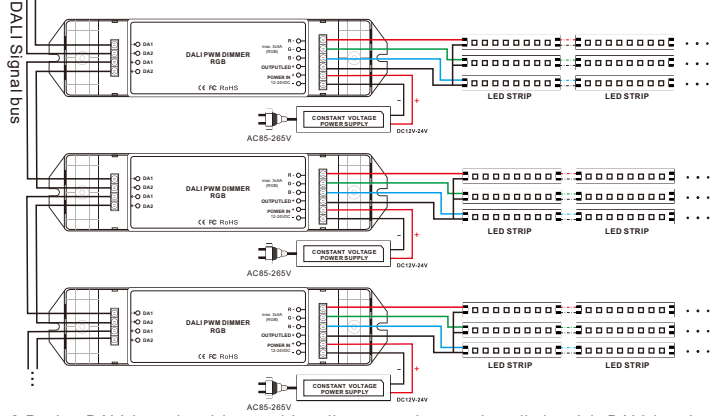

Diagram b:



2. Passive DALI bus signal input wiring diagram a: (no need to distinguish DALI bus is anode or cathode)

